



FEDERAL SUPERANNUATES NATIONAL ASSOCIATION

North Vancouver Island Branch

Mailing Address: FSNA North Vancouver Island Branch

P.O. Box 1420, Comox BC V9N 7Z9

President: Ian Sibbald, 2914 Suffield Rd., Courtenay BC V9N 3V6, 334-4451

Email: sibluc@shaw.ca

Editor: Kevin Weighill, 2173 Varsity Dr., Campbell River BC V9H 1V2, 926 6032

Email: kpweigh@telus.net

Editorial Assistant: Bernie Guyader



Representing retired employees and spouses from the Public Service of Canada, the Canadian Forces and the Royal Canadian Mounted Police

Newsletter No. 34 June 2007

Canada Post Publications Mail Agreement No. 40033460



From the Editor's Desk

From the Editor's Desk – September 2007 Edition

Have you ever wondered about the differences in artificial sweeteners, struggled measuring a diagonal, or wondered about the warning signs of stroke? Well look though this edition and you will find some information on these and other topics. As always if you have comments or concerns about what you see in the newsletter or if you have something you would like to see added, please don't hesitate to contact me.

CONTENTS

Editorial	1
President's Corner	2
Membership	3
PSHCP (Change).....	4
Warning signs of stroke.....	5
The Pope and Ah Peh.....	6
Hello Phoners.....	7
Shop Tips.....	7
\$250.00 Draw.	7
Artificial Sweeteners.....	8

Welcome to third edition of 2007. This will be my second last edition as the editor as I am resigning after I complete the December issue. If any of you would be interested in taking on the editorship of the newsletter, please contact our President Ian Sibbald or any of the current executive of our branch and let him/her know your interest. You can always contact me for information on what is involved in producing the newsletter as well. The e-mail addresses as well as the addresses and phone numbers of the executive are listed in every

issue of the newsletter.

**MEETING
DATES**

13 June 2007

*19 Sept. 2007

*Note Date Change

12 Dec. 2007

Please note the article by our Health Benefit Officers.

Don't hesitate to contact them with your questions.

I hope that you find this edition informative and interesting.

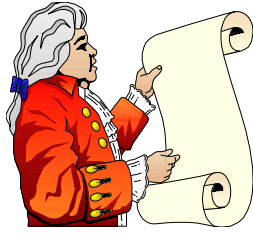

Ian Sibbald

PRESIDENT'S CORNER

The big convention is all over! From our point of view, we won a few and lost a lot. Without going into a lot of detail, we opposed "weighted voting" but lost out to the bigger Branches. For all the details of the gathering, see your next 'On Guard'. We did meet all sorts of fellow members from across the country and picked up many useful ideas. Our Regional Director, Al Dawber, will provide more detail at the September Meeting.

On a different matter, we occasionally get correspondence or calls from folks who are concerned about how our "Affinity" program works. Affinity is simply a term to describe a partnership between FSNA and a business firm. The best known example is MEDOC.

The concerns centre around items mailed to members promoting a given product. To the best of my knowledge, FSNA pays for neither the subject matter nor the postage for these mailings. Moreover, we keep control of the members names and addresses so that privacy is not compromised. Another concern involves the financial aspects. Again, I am informed that FSNA receives substantial financial contributions at the national level from firms with whom we do business.

In summary, Affinity provides quality service and products to members at reasonable prices and our national finances are enriched by rebates from the firms providing the services. In my view, it is a total win/win situation for both the individual member and FSNA as a whole.

Finally, a couple of notes closer to home. We will be holding the elections of our Executive at the December meeting. As always, we are searching for members who are willing to give a little back by serving. If you are interested, please contact any member of our current Executive. Also, don't forget that our Christmas Luncheon is by pre-purchased ticket only so, either pick up your tickets at the September Meeting or contact an Executive member to purchase them. See you at the September Meeting.

A Reminder, if you agree to attend a General Meeting Luncheon and subsequently change your mind. You **must** inform Barbara Schneider (250) 703-2504. If you don't**you will be billed for the cost of the meal !!!**

FSNA NORTH ISLAND EXECUTIVE

President	Ian Sibbald	334-4451	sibluc@shaw.ca
Vice-President	William McSeveney	(250) 923-6806	mc7ey@telus.net
Past President	Bernard Poole	339-5349	berniepoole@shaw.ca
Secretary	Dorothy Lind	339-6065	brydor@shaw.ca
Treas. & Membership	Tom Dandeno	339-3849	sinbad29@shaw.ca
A/M'ship.& Web Master	Steve Bunyan	897-1181	sgbunyan@shaw.ca
Newsletter Editor	Kevin Weighill	(250) 926-6032	kpweigh@telus.net
Editorial Assistant	Bernie Guyader	338-5267	gloc@shaw.ca
Welfare	Halle MacMullen	897-3893	hmacmullen@shaw.ca
Telephone	Cecile Turnbull	338-1857	bc.turnbull@shaw.ca
Programs	Barbara Schneider	703-2504	
Historian	Frank Elvins	339-4626	
Media	John Davis	339-4229	johnldav@shaw.ca
Health & Benefits	John Finn	338-7419	johnfinnandassociates@yahoo.ca
Assistant Benefits Officer	Doug Runchey	335-2296	dogger1953@yahoo.com
Director	Audrey Clarke	334-3416	turtleneck@shaw.ca
Director	Mary Kamann	334-4651	

MEMBERSHIP

A reminder to those members who pay by cash/cheque.

There are still a few of you who have not renewed for 2007. You have already received a personal reminder and this will be the last formal reminder. As of 30 June, your membership will be terminated as required by our bylaws. I am still receiving new data from last fall's membership campaign, if you changed to DDS during that campaign, I may not yet know about it. Please contact me to avoid a problem. Also, if you do not intend to renew, please contact me so that I can close your file. Thanks for the help.

September Luncheon News (price increase)

The Catering Manager of the Best Western Westerly Hotel has informed the FSNA Executive that a pending **price increase** for our luncheon meals at our quarterly meetings **will start in September**.

The new luncheon costs will be **\$15.00 per person**, up \$2.00, from the current \$13.00. This includes the buffet with dessert, tea, coffee, the room rental, gratuity and tax. Members can still attend the business part of the meeting starting at 1:00 p.m. at no cost.

Please remember that ticket sales for the Christmas Luncheon are going well and the executive will be selling these tickets again at the September meeting. After this you can contact any executive to see if tickets are available. The **cost is \$15.00 per person** on the pre-sale tickets for our Christmas Luncheon. ***Please note that there will be no tickets sold at the door for the December meeting for the Luncheon portion.***

We will be having several draws at the December Luncheon, which includes a Door Prize, the 50/50, the \$250.00 e-mail draw and 50 gift draws from Santa. As it is always nicer to give than to receive, especially at Christmas time, a special **Food Bank draw** will be held. We are requesting that each couple brings one item for food bank and if you do, you will receive one free ticket for a Special Draw.

Please buy your Christmas Tickets early (available at the September meeting), as we can accommodate no more than 300 members.

Hope to see you at the September Meeting.

Barb Schneider
Programs

MEMBERSHIP UP-DATE

Do we have the correct information on you as a member?

It is important to us and to you that our records are up to date. If the label on this newsletter has your INITIALS instead of your given name, we may not have all the information we need to ensure that you get all the updates from your branch or National Office.

Please fill in the following and send it to us (address on Page 1).

Surname Given names:.....

Mailing address:

City/town Postal Code Phone

Pension is from: CF PS RCMP Other I receive a survivor's benefit Yes..... No

It is important to let the branch know of any changes in the above information

A change to the Public Service Health Care Plan (effective 1 April 2006) permits both spouses of a family to join the plan individually if they are both federal government pensioners (PS, CF, RCMP or federally appointed judges). This provision allows the co-ordination of benefits between spouses i.e. one spouse can claim 80% of eligible medical costs and the other spouse, the remaining 20%.

Branch Health Benefits Officers are frequently asked what is the most cost effective method in such cases i.e. two single coverage, two family coverage, one family and one single coverage, or one family coverage. Unfortunately, this is a difficult question to answer. One has to consider a number of factors before selecting the most cost effective scenario.

- a. The membership cost of a “single coverage”: \$176.52/year vs. \$375.60/year for the “family coverage”;
- b. The annual deductibles of both plan coverage: \$60 for single and \$100 for family.
- c. The average medical expenses of each spouse in the last three or four years, and
- d. Whether one spouse’s medical expenses are much greater than those of the other spouse.

The following chart illustrates the total cost of various combinations of coverage. It also indicates examples where the annual medical expenses are equally divided or if one spouse has more expenses than the other i.e. 75% vs. 25% of all medical expenses. In this last case, if the best scenario is one “family coverage” and one “single coverage”, it is always financially advantageous for the spouse with the greater amount of medical expenses to have the “single coverage” while the other spouse has the “family coverage”. To obtain the final calculations of the chart, various factors such as annual eligible medical expenses, annual deductible amounts, amounts reimbursed by the plan and membership fees.

Total cost per type of coverage per year to the Family

\$1000 total expenses \$1500 total expenses \$3000 total expenses

	50%/50% Expenses \$	25%/75% Expenses \$	50%/50% Expenses \$	25%/75% Expenses \$	50%/50% Expenses \$	25%/75% Expenses \$
2 single coverage	649	649	749	749	1049	1049
2 family coverage	715	715	715*	715	715*	715*
1 single & 1 family coverage	714	664	764	689*	914	764
1 family coverage	638*	638*	738	738	1038	1038

*** indicates the lowest cost option in each category**

The above chart illustrates that in a case where the family claimed expenses are low, the member is better off having the one “family coverage”. In fact, according to my calculations, the break-even point is approximately \$1,400 of annual claimed expenses where a family should consider having two “family coverage”. Although it is marginally cheaper at \$1500 of eligible expenses to have one “single coverage” and one “family coverage” where the “single coverage” member has 75% of the medical claims, it is progressively cheaper to have two family plans thereafter.

Another factor that must be considered is if one or both members have individual expenses in excess of the maximum allowed by their plan.(i.e. glasses, massage therapy, psychological services etc) then the other family member can claim the balance up to their own plans maximum. For example, if a member has \$2,000 in psychological costs with two plans the family can be reimbursed \$1,600 rather than the \$800 allowed by one family plan (80 % of the \$1,000 maximum claimable expenses on each plan).

In summary, is the member better off financially having one “family plan” or if both spouses have separate plan coverage? Based solely on financial consideration, the figures seem to indicate that if claimable medical expenses are less than \$1500 per year, the member is financially better off in having one “family plan”. As medical expenses increase above \$1500 per year, the member may consider separate coverage for each spouse whether two “family coverage” or one “single coverage” and one “family coverage”.

If your claimable expenses are greater than \$1500 per year, and if you expect that this will continue in the future, may I suggest that you contact John Finn, Branch HBO or Doug Runchey, Assistant Branch HBO. Either one of us can help you calculate whether it is worth your while to remain with or change the plan coverage that you presently have.

John Finn
Branch HBO
338-7419

Dough Runchey
Assistant Branch HBO
331-0051

Warning signs of a stroke

- *Weakness* - Sudden loss of strength or sudden numbness in the face, arm or leg, even if temporary.
- *Trouble speaking* - Sudden difficulty speaking or understanding or sudden confusion, even if temporary.
- *Vision problems* - Sudden trouble with vision, even if temporary.
- *Headache* - Sudden severe and unusual headache.
- *Dizziness* - Sudden loss of balance, especially with any of the above signs.

The Heart and Stroke Foundation advises you call 9-1-1 or your local emergency number immediately if you experience any of these symptoms.

The Pope and Ah Peh

About a century or two ago, the Pope decided that all the Chinese had to leave Italy. Naturally there was a big uproar from the Chinese community.

So the Pope made a deal. He would have a religious debate with a member of the Chinese community. If the Chinese win, they could stay. If the Pope wins, the Chinese would leave.

The Chinese realized that they had no other choice. So they picked a middle-aged man named Ah Peh to represent them.

Ah Peh asked for one condition to be added to the debate. "To make it more interesting", he said, "neither side would be allowed to talk".

The Pope agreed. The day of the great debate came. Ah Peh and the Pope sat opposite each other for a full minute.

Then the Pope raised his hand and showed three fingers. Ah Peh looked back at him and raised one finger. The Pope waved his fingers in a circle around his head. Ah Peh pointed to the ground at where he sat. The Pope pulled out a loaf and a glass of wine. Ah Peh pull out an apple.

The Pope stood up and said: "I give up. This man is too good. The Chinese can stay."

An hour later, the cardinals were all around The Pope asking him what happened?. The Pope said, "first I held up three fingers to represent the holy trinity. He responded by holding up one finger to remind me that there was still one God common to both our religions."

"Then I waved my finger around me to show him that God was all around us." He responded by pointing to the ground and showing that God was also right here with us."

I pulled out the wine and loaf to show that God absolves all sin. He showed me an apple to remind us of the original sin. He had an answer for everything. What could I do?"

Meanwhile, the Chinese community had crowded around Ah Peh. "What happened?" they asked.

"Well," said Ah Peh, "First he indicated to me that all Chinese had 3 days to get out of here. I replied to him get lost and not one of us was leaving."

"Then he pointed that this whole city would be cleared of Chinese. I showed him that we are staying right here."

"Yes, and then???" asked the crowd.

"I don't know", said Ah Peh, "He took out his lunch, and I took out mine !!!!!!!!"

A great Canadian source of information for seniors is the Magazine "Good Times" published by Senior Publications Ltd, 25 Sheppard Ave West, Toronto, Ont, M2N 6S7. It is published 11 times a year. To subscribe call toll free 1-800-465-8443 Cost is \$21.95 + GST = 23.49 for 1 year. It is available at newsstands for \$3.25 per issue

Hello Phoners!

Members on the phone committee please remember.....

If you're going to be out of town prior to a general meeting and you're unable to phone the people on your list, please phone Cecile Turnbull at 338-1857 so that she can re-assign those names to another phone committee member. It is important that members know about upcoming general meetings, and it is important that we know whether or not they intend to come.

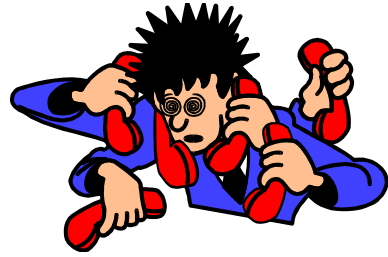

\$250.00 Draw!!!!

Would you like to receive the local FSNA Newsletter by e-mail instead of in the mail? We are trying to cut mailing costs and some members have already signed up. You are eligible to enter the draw by entering your e-mail address, name and phone number to Steve Bunyan at sgbunyan@shaw.ca. Those who have already submitted their name, e-mail address and phone # do not have to sign up again and will be included in the draw.

The draw for the winner will be made at the Christmas Luncheon. You do not have to attend to be the winner.

Measuring Diagonals Easily

The last step to assembling a case is to make sure it's square. And the quickest way to do this is to measure diagonally from corner to corner. (If it's square these measurements will be the same. If not, you'll need to make some adjustments.) Using a tape measure is an easy way to check for square. The problem is that keeping the end of the tape on the corners can be difficult. But with a quick modification to the hook of the tape you can solve this problem.

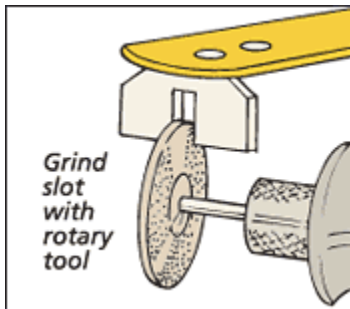

To do this, simply cut a small slot on the hook with a rotary tool (or hack saw), see the drawing above right.

The slot slips over the point of the corner of the project, see the drawing and detail at right. The slot holds the tape in place for those large projects where an extra set of hands would be a big help. And it doesn't effect the tape measure's accuracy when I use it for other projects. Good Woodworking,

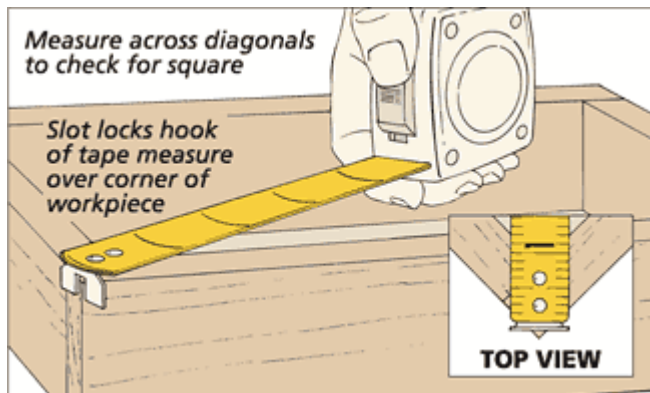

Ted Raife
Online Editor, *Woodsmith*
© August Home Publishing Company

The skinny on artificial sweeteners Article By: Jennifer Gruden

A look at common artificial sweeteners: just how safe are they?

Whether you're concerned about consuming too much sugar, looking to lose weight, or just plain shopping at the grocery store, the question of artificial sweeteners is everywhere. Here's a look at some of the most common, as well as a few on the horizon.

There are two basic categories of sweetener. Nutritive sweeteners provide energy (measured in calories) to your body and include sugar, honey, and syrups. These taste sweet because they contain glucose or fructose, or both together which form sucrose (table sugar), and impact on the body's blood sugar levels. Nutritive sweeteners also include a class of sweeteners called sugar relatives, which are made up of sugar alcohols. These are derived from fruits or produced commercially. They are recognizable because they end in -ol (for the alcohol): sorbitol, mannitol, xylitol and maltitol are some of the most common. These alcohols also contain energy (calories) and may impact on blood sugar. Artificial sweeteners are also known as nonnutritive, because they do not provide calories and will not influence blood sugars. These include: saccharin, aspartame, sucralose, cyclamate, and acesulfame potassium.

One of the questions about these sweeteners remains whether or not they are safe. But all of these have been approved by Health Canada, although some are restricted to particular forms or disallowed in certain foods. Each has a recommended daily intake that consumers should not exceed, which varies by weight and other factors. So if you are planning to use a lot of substitutes, it's a good idea to consult with a physician about what amounts remain safe.

Here's a look at common artificial sweeteners individually.

Saccharin is the oldest of the nonnutritive sweeteners – in fact, it was discovered in 1879 at John Hopkins University. Saccharine is available in Canada but only as a stand-alone sweetener (not as an ingredient in calorie-reduced foods, such as diet soft drinks). It is commonly found in the “little pink packet” under the brand name Sweet’N’Low® and is also sold in tablet or powder form in pharmacies. It is 300 times sweeter than sucrose but has a slightly bitter/metallic aftertaste. Because saccharine is not metabolized in the human body, it does not contribute energy or calories. During the 1960s and into the 1970s a number of studies were conducted to examine the link between saccharine and cancer, particularly bladder cancer, and it was one of these studies which led to Canada banning its presence in calorie-reduced foods. The cancer link has not, however, been proven in subsequent studies.

Aspartame is marketed for commercial use under the brand name NutraSweet™ and Equal™ is found in a wide variety of foods, including breakfast cereals, soft drinks, desserts and candy, and sold as a powder for home cooking. It does not survive heat very well and so is rarely used in baked goods. Aspartame does contain calories, but because it is 200 times sweeter than sugar and very little is needed to achieve sweetness, it adds so few that it is essentially non-nutritive.

Aspartame is made up of two amino acids: aspartic acid and phenylalanine, both of which are found in proteins. When digested, it breaks down into methanol (wood alcohol). Some people have been very vocal in their belief that aspartame is not healthy can produce side effects such as migraines and chronic fatigue, but this has yet to be scientifically proven. A 2005 study did however link aspartame in high amounts to lymphomas and leukemia in female rats, but like the saccharine studies, this is not conclusive about risks to human beings. People diagnosed with phenylketonuria (PKU), a rare hereditary disease, should not consume aspartame.

Sucralose is more pervasive in Canadian foods. Marketed as Splenda™, it is available as a tabletop sweetener and as an ingredient in food processing. Sucralose is 400 to 800 times sweeter than table sugar, and is made from sugar itself. Because of molecular differences between sucralose and sugar, the body cannot break it down, and so it is non-nutritive.

Because it is stable even when very hot or cold, sucralose can be used in a variety of cold and hot drinks, pastries and baked goods, and frozen and canned fruits and vegetables. Although its chemical structure is very close to that of sucrose or table sugar, sucralose is not recognized by the body as a carbohydrate and doesn't raise blood sugar levels.

Cyclamate is marketed under the brand name Sucaryl™ and is present in Sugar Twin™ and Weight Watchers™. This sweetener is 30 times sweeter than sugar. In Canada, cyclamate can only be purchased as a tabletop sweetener or as a sweetening additive in medication.

Acesulfame Potassium (AceK) is the most recent nonnutritive sweetener to be approved by Health Canada. It is marketed under the brand name Sunett™. AceK is found in beverages, fruit spreads, baked goods, dessert bases, tabletop sweeteners, hard candies, chewing gum and breath fresheners. It is 200 times sweeter than table sugar. There have been concerns raised that it may affect the thyroid.

People who are on a potassium restricted diet or have sulfa-antibiotic based allergies should avoid AceK.